

Vortex Flow Sensor VA40 ZG8 Ex-d



höntzsch
flow measuring technology

Vortex probe VA for flow measurement of gases with integrated, configurable transducer UVA in Ex-d housing



Probe VA40 ZG8 as an example with flange guide piece SFB

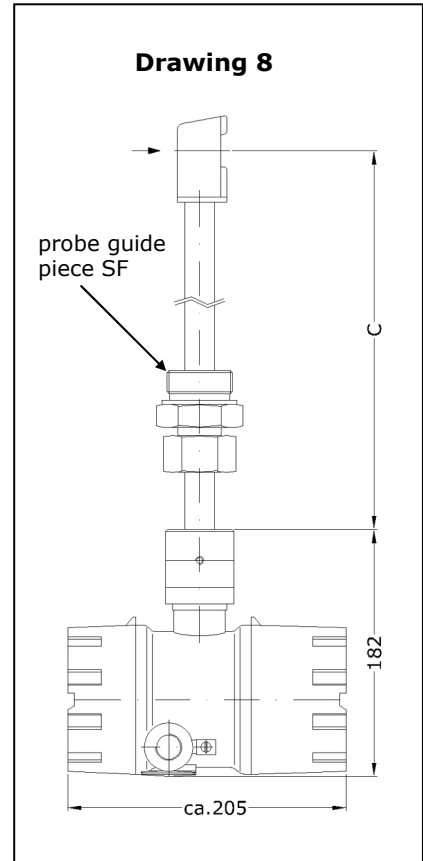

Probe, as an example, with screw thread probe guide piece SFB

Measurable variables

- actual flow velocity v [m/s]
- actual flow rate [m³/h] in
- conversion to standard velocity/standard volume flow by entering working pressure and temperature parameters

Medium

- primarily single-phase gas mixtures with air, nitrogen, oxygen, methane, natural gas, ammonia, argon, carbon monoxide, superheated steam ... as dominant components, biogas.
- Other gases or gas mixtures on request.

Measuring range

- 0.5 ... 40 m/s

Functional principle

- vortex meter for measuring flow velocity, flow rate and volume
- ultrasonic measuring of the vortex shedding



Kármán vortex street

Design

- insertion probe with probe guide piece and Ex-d housing

Advantages

- compact measuring instrument with optional on-site display in Ex-application
- application in category 1 (zones 0 and 20), transducer housing approved for category 2 (zones 1 and 21)
- no external isolation/supply unit necessary
- minimal reaction time (0.5 m/s)
- high measuring dynamics (1:80)
- steady long-term measuring
- no moving parts
- easy to clean
- high fatigue strength
- corrosion resistant
- operates to a large extent irrespective of gas composition
- minor pressure drop
- easy configuration via HART[®]-interface

Examples of application

- flow measurement in Ex-application, for example, of air, outgoing air, sludge activation air, engine intake air, natural gas, exhaust gas, process gas, biogas, motor car exhaust, torch gas, water vapour

Particles, humidity and condensation

- charges in the gas caused by particles such as dust and fibres do not affect measurement, as long as abrasion and agglomeration do not occur on the sensor
- relative gas humidity of less than 100 % and slight condensation on the sensor do not affect the measurement uncertainty



Model designation (example)

VA40	G	E	40 m/s	p3	ZG8	Ex-d
(1)	(2)	(3)	(4)	(5)	(6)	(7)

Types

Type	Article No.
VA40 GE 40 m/s p3 ZG8 Ex-d	b009/000
VA40 GH 40 m/s p3 ZG8 Ex-d	b009/001
VA40 GT 40 m/s p3 ZG8 Ex-d	b009/002

(1) Sensor type / diameter

Vortex flow sensor VA40: sensor head width across corners 40 mm and shaft Ø 21.3 mm for insertion in openings with a diameter greater than 40 mm

(2) Medium

... G ...	air / gases
-----------	-------------

(3) Materials in contact with the medium

Design	Material
... E ...	stainless steel, sensor housing 1.4581, connection tube 1.4404, ceramics, seals VITON [®] , sensor silicone-free
... H ...	Hastelloy 2.4610 / HC4, ceramics, seals VITON [®] , sensor silicone-free
... T ...	titanium 3.7161, ceramics, seals VITON [®] , sensor silicone-free

(4) Measuring range

Design	Range
... 40 m/s ...	0.5 ... 40 m/s

Measuring uncertainty < 1.0 % of measured value + 0.03 m/s

Repeatability ± 0.2 % of measured value + 0.025 % of terminal value

For examples of measurable volume flows see Table on Page 3



Examples - measurable volume flows (s. also under (4), Page 2)

measuring tube inside diameter Di [mm]	profile factor PF* [-]	smallest measurable value [m ³ /h]	terminal value [m ³ /h]
80	0.719	6.5	520
100	0.738	10.4	835
120	0.761	15.5	1240
150	0.796	26	2030
200	0.842	48	3810
300	0.845	108	8600
400	0.850	193	15400
500	0.850	300	24000
750	0.850	680	54100
1000	0.850	1200	96100
1250	0.850	1880	150000
1500	0.850	2700	216000

Volume flow measuring range specifications with centric positioning of the sensor, irrotational afflux and, amply dimensioned input / output sections (see Instruction Manual).

* The profile factor PF describes the ratio of average flow velocity in the measurement cross section and the flow velocity measured from the sensor. The afore-mentioned operating conditions apply.

Working temperature range / gasket material

Design	Material	Working temperature range of the medium	Art. No.
't_{max} +100 °C'			
	VITON®	-20 ... +100 °C	b009/080
	silicone	-40 ... +100 °C	b009/081
	EPDM®	-40 ... +100 °C	b009/082
	KALREZ®	0 ... +100 °C	b009/083
't_{max} +180 °C'			
	VITON®	-20 ... +180 °C	b009/090
	silicone	-40 ... +180 °C	b009/091
	KALREZ®	0 ... +180 °C	b009/092

Permissible ambient temperature -20 ... +50 °C

** Compound 4079



(5) Max. working pressure

up to 3 bar / 300 kPa above atmospheric

(6) Design

as in Drawing 8 (Page 1)

(7) Ex-protection

for gas : Ⓢ II 1/2 G Ex ia/d e [ia] IIC T6 Ga/Gb and

for dust : Ⓢ II 1/2 D Ex ia/tb IIIC TX Da/Db

Sensor for applications in Category 1 (Ex-Zone 0 or 20)

Transducer housing for applications in Category 2 (Ex-Zone 1 or 21)

Installation length (see Drawing 8, Page 1)

Measurement C	for sensor in		
	stainless steel '... E ...'	Hastelloy '... H ...'	titanium '... T ...'
	article no.	article no.	article no.
250 mm	b009/050	b009/060	b009/070
500 mm	b009/051	b009/061	b009/071
750 mm	b009/052	b009/062	b009/072
1000 mm	b009/053	b009/063	b009/073
1250 mm	b009/054	b009/064	b009/074
1500 mm	b009/055	b009/065	b009/075
1750 mm	b009/056	b009/066	b009/076
2000 mm	b009/057	b009/067	b009/077

The correct installation length must be chosen, so that the surface temperature of the transducer housing does not exceed +50 °C!

Ex-d transducer housing

Dimensions	outside diameter/length/height: ca. 110/205/182 mm
Material	die-cast aluminium max. 0.5 % Mg, coated housing
Type of protection	IP68, IEC 529 and EN 60 529
Connection	bush for shielded cables with external diameter 5 ... 9 mm, contacting of the overall shielding on the earth terminal in the housing; connection via screw-type terminals Ex-e for wires with cross-section 0.14 – 1.5 mm ²
Orientation to the sensor	rotatable by approx. 350 ° and lockable
Setup	dual chamber system, consisting of 1) electronics in Ex-d protection (pressure-resistant casing) and 2) connections in Ex-e protection (increased safety) with terminal block and bush

Electromagnetic Compatibility (EMC)

according to EN 61 000-6-2 / IEC77

Mounting attitude

any if condensation on the sensor cannot be ruled out, a horizontal attitude is recommended



Probe guide pieces* (see Page 6)
Model designation (examples)

SFB	21.3		E	53	G1 1/2"	ZG5
SFK	21.3	/42	E	150	F-DN50PN16	ZG3
(S1)	(S2)	(S3)	(S4)	(S5)	(S6)	(S7)

(S1) Type	
SFB	SF with bushing
SFK	SF with clamping yoke
SFZ	SF with collet
(S2) Diameter through hole [mm]	
... G ...	air / gases
(S3) Diameter insertion opening for probe	
(S4) Material	
... E ...	stainless steel
... H ...	Hastelloy
(S5) Installation length L [mm]	
(S6) Process connection type	
... G ...	thread
... F ...	flange
(S7) Design as in Drawing(ZG)	

Type	Description	Article No.
with screw thread connection		
SFB 21.3 E-53 / G 1½" ZG5, see Drawing 5, Page 6	VITON® seal, TEFLON® bushing, working temperature range -20 ... +240 °C, max. working pressure 3 bar/300 kPa, thread length GL 22 mm	b004/504
SFB 21.3 E-53 / G 1½" ZG5 with metallic sealing edge, see Drawing 5, Page 6	metallic sealing edge, TEFLON® bushing, working temperature range -40 ... +240 °C, max. working pressure 3 bar/300 kPa, thread length GL 22 mm	b004/511
SFB 21.3 E-53 / NPT 1½" ZG5, see Drawing 5, Page 6	VITON® seal, PTFE bushing working temperature range -20 ... +240 °C, max. working pressure 3 bar/300 kPa, according to ANSI/ASME B1.20.1-1983, thread length GL approx. 26 mm	b004/509
with flange connection		
SFB 21.3 E-70 / F-DN50 PN16 ZG1, see Drawing 1, Page 6	seal TEFLON® bushing, working temperature range -20 ... +240 °C, max. working pressure 3 bar/300 kPa	b004/103
SFB 21.3 H-70 / F-DN50 PN16 ZG1, see Drawing 1, Page 6	seal TEFLON® bushing, working temperature range -40 ... +240 °C, max. working pressure 3 bar/300 kPa	b004/105
SFB 21.3 E-70 / F-ANSI B16.5 2" 150 lbs ZG1 see Drawing 1, Page 6	seal TEFLON® bushing, working temperature range -40 ... +240 °C, max. working pressure 3 bar/300 kPa, flange according to ANSI Standard B16.5	b004/512



Probe guide pieces* (cont.)

Type	Description	Article No.
SFK 21.3 E-150 / F-DN50 PN16 ZG3, see Drawing 3	PTFE lip-seal with HC4 spring, working temperature range -20 ... +240 °C, max. working pressure 6 bar/600 kPa, incl. hexagon cranked wrench key SW5	b004/304
SFK 21.3 E-150 / F-DN40 PN16 ZG3, see Drawing 3	PTFE lip-seal with HC4 spring, working temperature range -20 ... +240 °C, max. working pressure 6 bar/600 kPa, incl. hexagon cranked wrench key SW5	b004/303
SFK 21.3 / 42 E-150 / F-DN50 PN16 ZG3 with ball valve, see Drawing 3	PTFE lip-seal with HC4 spring, working temperature range -20 ... +240 °C, max. working pressure 6 bar/600 kPa, with ball valve, installation length ball valve 150 mm, incl. hexagon cranked wrench key SW5. In order to close the ball valve, the sensor may be retracted into the probe guide piece	b004/313

* Probe guide pieces are obligatory for process connection via screw socket or single ended flange nipples. They are slidable, rotatable and non-detachably connected with the probe shaft. It is to be ensured that sensor length, screw socket or flange nipple height as well as probe insertion depth match up. Other probe guide pieces on request.
'aA' : price on request

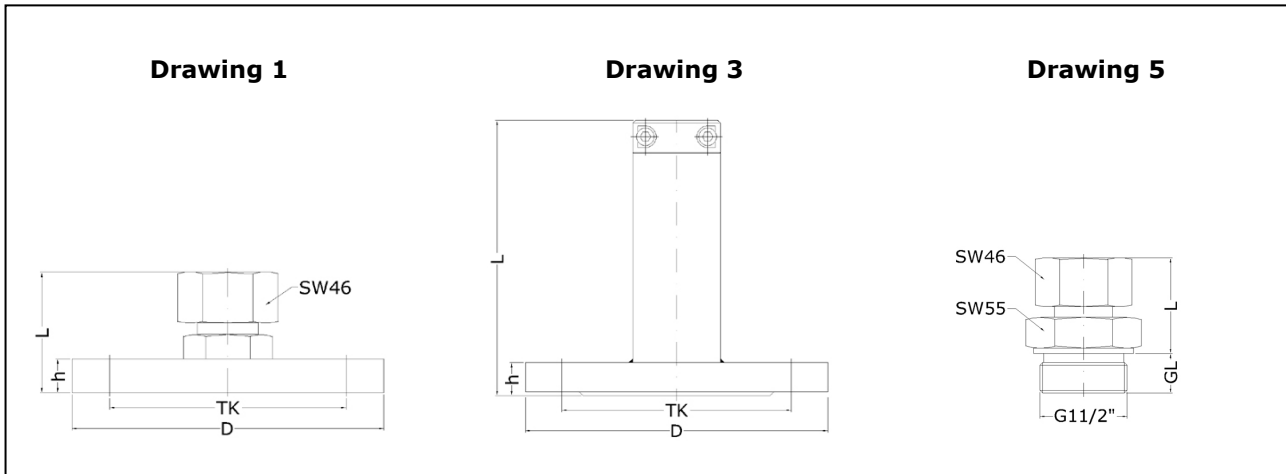

Probe guide pieces SF



Transducer UVA, integrated in the connection housing

Analog output flow	4 ... 20 mA working resistance max. 500 Ohm
Output limit value or quantity pulse	potential-free relay contact (normally open contact), max. 300 mA / 27 VDC
Communication port	HART®, via modem adapter for PC connection and PC software UCOM (see Accessories)
Self-monitoring	output signals are electrically isolated from the power supply parameter settings, sensor interface; in the case of error: analog output less than 3.6 mA
Power supply	24 V DC (20 ... 27 V DC)
Power consumption	less than 5 W
Setting parameter (selection depending on parameter set)	analog output, time constant, profile factor, tube inside diameter, limit value or quantity pulse (quality rating adjustable), switch-over actual/standard flow with setting parameters 'working pressure' and 'working temperature'



Ex-d transducer housing with optional LCD display

Accessories (optional)

	Description	Art. No.
LCD display	1 st line: 'instantaneous value': flow rate or flow velocity 2 nd line: 'counter' or 'error code'; 2 x 16-digit, character height 5.5 mm, working temperature range -20 ... +50 °C display rotatable in 90 °-stages on removing the Ex-d housing window cover	a010/520
Calibration certificate v/VA		klbneu
HART® modem adapter	for changing the setting parameter, for PC-USB connection	a010/101
HART® modem adapter	for changing the setting parameter, for PC-RS232 connection	a010/102
PC software UCOM	for configuring the UVA via RS232	a010/052



Probe installation

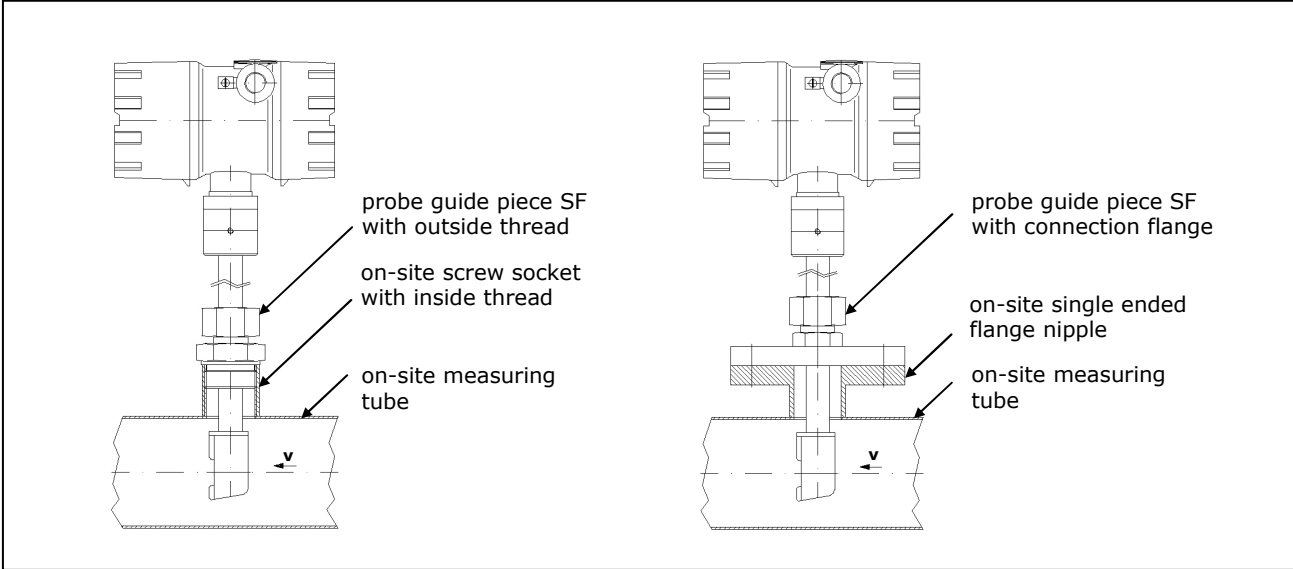

Probe installation with screw thread probe guide piece (left) and flange probe guide piece (right)